

# RO

Hotmelt coating technology  
Coating heads FKV, FK SX, FK-IT, FKW, ETV



**Robatech**  
Gluing Technology

# Coating heads FKV, FK SX, FK-IT, FKW, ETV

Top coating quality

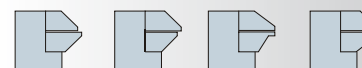
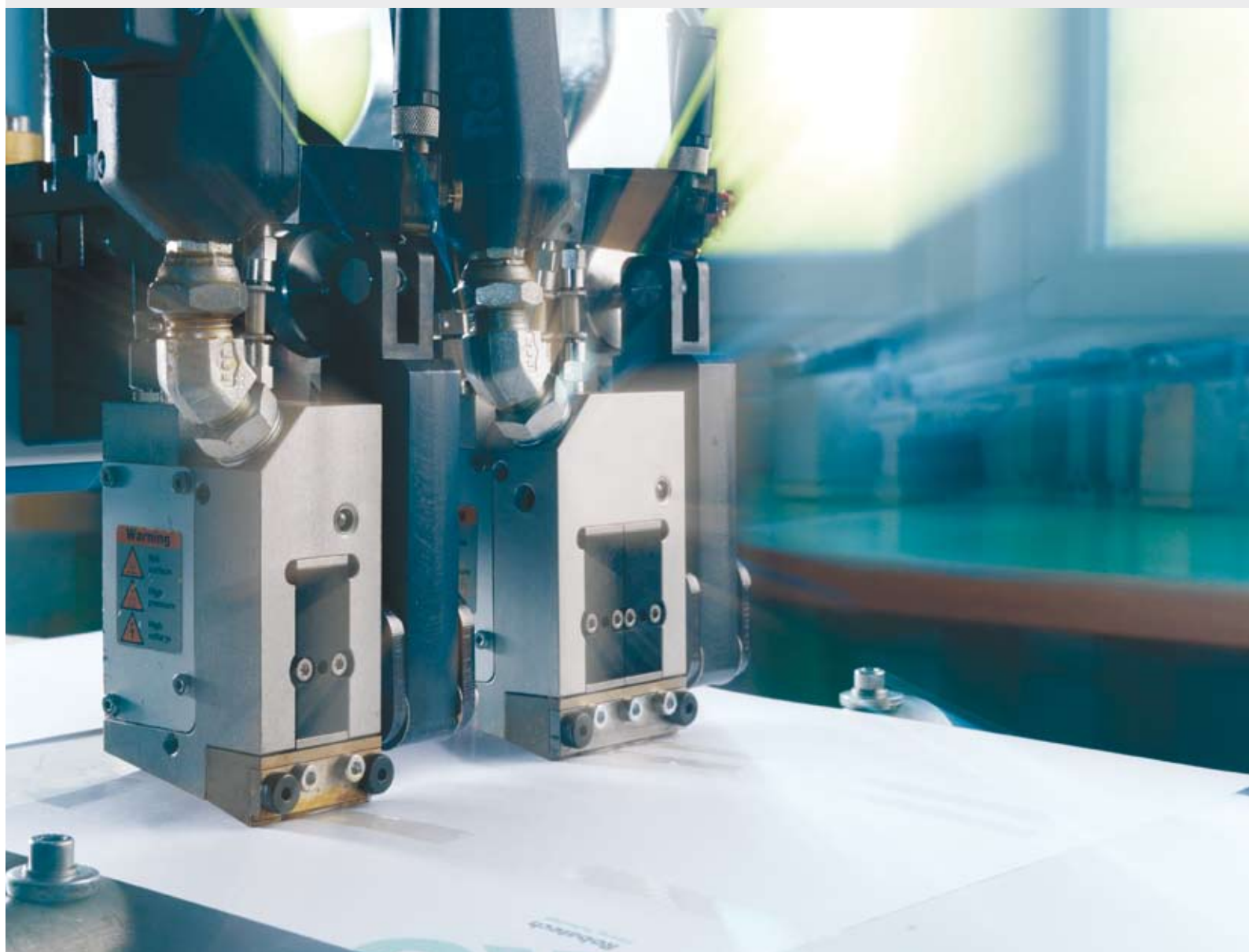

## Porous, full-surface, endless, interrupted

**In many cases the hotmelt coating technique replaces systems working with water or solvents based adhesives. Since hotmelt coating requires no drying or evaporation, the energy consumption is reduced. Various hotmelts such as EVA, PSA, PUR, APAO, etc. are suitable for a porous or full-surface application with the slot-type nozzle, followed by lamination.**

The challenge here is the processing of the hotmelts according to FIFO (first in, first out) method in a closed system which meters precisely and doesn't need any cleaning.

We achieve highest reliability and precision due to:

- Various lip geometries
- Aftertreatment of the lips
- Correct material choice for the nozzle
- Accurate temperature control
- Optimal adhesive distribution

Equally decisive for the perfect application is a solid, expansion-compensated suspension of the nozzle. The nozzle itself, its position and adjustment possibilities contribute decisively to the top coating result.

### Coating heads FKSX / FK16 (intermittent)

- Small, compact design
- Good cut-off
- Integrated filters
- High switching frequency
- Simple adjustment
- Easy to clean
- Short setup times
- Suspension for folding machine

### Coating heads FK-IT (intermittent)

- Good cut-off behaviour
- Snuff-back technique
- Highest switching capacity
- High durability

### Coating heads FKW60 / ETV (intermittent, vertical)

- Vertical application position
- Stepless height adjustment
- For PUR, PSA, APAO, EVA
- ETV especially for box labelling
- FKV 60 for edge gluing and book binding

### Coating heads FKV (endless)

- For continuous coating
- Stepless width adjustment or with mask and adapted distribution
- Short change-over times
- Perfect temperature control
- Little maintenance required
- Reduced consumption, less waste
- Well-proven modularity
- Manual or motor-driven adjustment

### Coating heads FK Gel (endless)

- All parts coming into contact with materials are of FDA-grade stainless steel (for foodstuffs)
- Maximum 100 °C
- Precise distribution over full width
- For thick application

**...and Made in Switzerland, of course.**

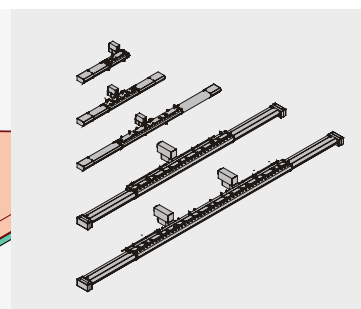
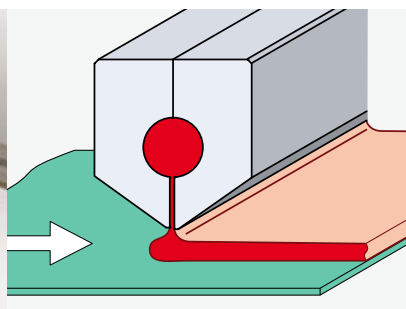
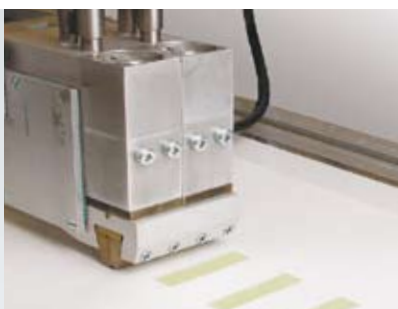

Our know-how in coating is your productivity

**The perfect connection: No matter whether continuous or intermittent, small or large quantity to be applied, self-adhesive or reactive, fixed or adjustable application width. We have the right solution among our coating heads FKSX, FK-IT, FKV, FKW, ETV.**

#### Modularity and compatibility

We cope with all requirements by resorting to different geometries, but we always use the same components such as filters, cartridge heaters, adjustment units, etc.

#### The slot-type nozzle is crucial

Years of experience in nozzle coating have taught us that it is the nozzle that matters. The right steel grade combined with tightest machining tolerances and the best surface treatment guarantees the best results.

#### Precision bracket

A sturdy, fully adjustable mounting is necessary so that the coating nozzle can be aligned precisely to the product sheet. Different solutions are available depending on requirements.

#### Low maintenance costs

Robatech coating heads stand out by their superior durability and their suitability for an extremely inexpensive operation. This is because we use operationally safe components tailored to the particular requirements, rely on sturdy designs and offer an exchange service for nozzles and filters.

#### Expertise from one source

Our test lab contains three coating systems offering application widths of 300/500/2600 mm. We develop, test and provide samples of your products. Experienced Project Managers accompany you right to the machine acceptance phase. And, of course, a process performance guarantee is available.

#### Partnership

The following parameters must be considered in coating projects:

- Adhesive
- Coating system
- Substrates to be coated
- Performance characteristics
- Coating nozzle

Robatech builds not only the best coating heads, we also cooperate with well-known material, equipment and adhesive suppliers.

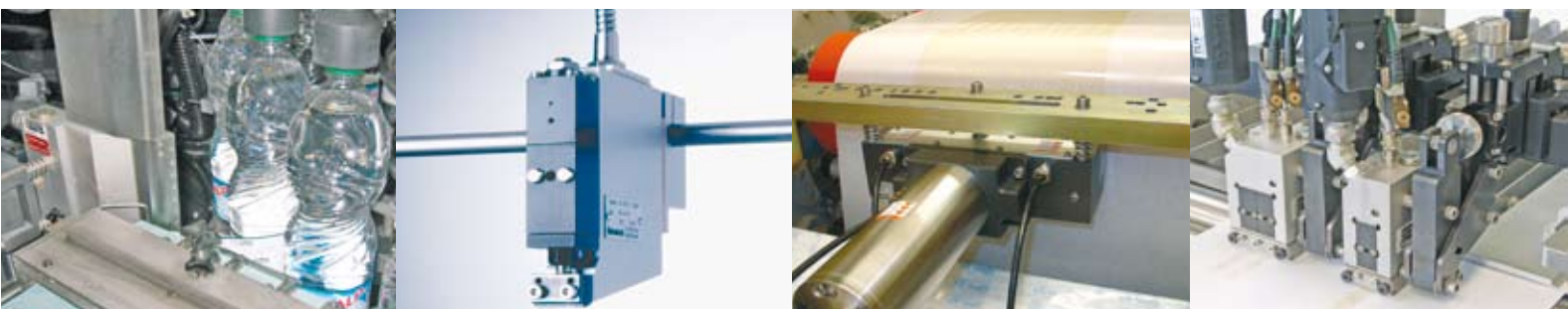

## The result of know-how and competence

**We know how to apply adhesives. We've been doing this successfully for more than three decades. This is how we achieved a first-class reputation: quality assurance, backed by superior service with know-how and competence.**

We draw from this experience for the development of all Robatech products, including the ones used in coating technology. We advise you from the project phase right through to production.

Our coating heads come in numerous combinations and offer the right possibilities to cope with all requirements.

In our production – certified to comply with ISO 9001:2000 – we use nothing but top-quality, well-proven materials and rely on the latest manufacturing techniques. In combination with quality-related procedures and inspections the result is exactly what you're looking for:

**Highest productivity at low life-cycle costs.**

## All you need for your production Options and accessories



We supply you with absolute top-grade products and support you with our knowledge and experience. Further services are available on request. Let's talk to each other – for example about:

**Electrically driven adjustment units**

**Bracketry FKV**

**Bracketry FKSX**

**Replacement nozzles**

**Filter unit**

**Quantity control**

**Different lip shapes**

**Special solutions**

**Service**

**Training**

**Preventive maintenance**

Headquarters  
Robatech AG  
Pilatusring 10  
CH-5630 Muri  
Switzerland  
Tel. +41 56 675 77 00  
Fax +41 56 675 77 01  
info@robatech.ch  
www.robatech.com

Robatech U.K. Limited  
The Street, Broughton Gifford  
Melksham  
UK-Wiltshire SN12 8 PH  
Tel. +44 1225 783 456  
Fax +44 1225 783 400  
general@robatech.co.uk  
www.robatech.co.uk

Robatech USA Inc.  
11660 Alpharetta Hwy  
Roswell, GA 30076  
USA  
Tel. +1 770 663 83 80  
Fax +1 770 663 83 81  
info@robatechusa.com  
www.robatechusa.com

**Robatech**  
Gluing Technology